



## Type 1 Fitting Instructions

*After fitting, please keep these instructions with your other vehicle papers. Should you ever accidentally damage your RAK system or purchase another vehicle, your customer number will help us to provide you with the correct replacement parts.*

Congratulations on your choice of RAK, Australia's No.1 roof rack system.

As a RAK owner, you now have a versatile system that can be transferred from one vehicle to another. Unlike most roof rack systems, your RAK telescopic roof bars adjust to fit almost any similar vehicle. Should you wish to transfer them to a vehicle with a different roof profile, parts are available to adapt your racks to most vehicle types.

Your purchase has been recorded along with your vehicle details. When you change vehicles, or if you wish to use the racks on more than one vehicle, just quote your customer number and the new vehicle details and we'll tell you which parts you will need to order.

We hope you'll be so pleased with your racks that you'll recommend RAK to friends. When you do, ask them to quote your customer number and we'll credit you with \$10 to use against future purchases of adaptors, accessories or a second set of racks.

Customer number .....  
Enter your Customer Purchase Order number here

Manufactured in Australia by RAK Australia, PO Box 588, Mona Vale Sydney NSW 2103  
Tel +61 2 997 2311 Fax +61 2 997 3533 e-mail: sales@roofracks.com

# roofracks.com

Your RAK roof rack system is supplied assembled and ready to fit. Included in the pack are two racks, each comprising a telescoping roof bar **1** with fitted ends **2**. Note that the bars have an aerofoil shape and should be fitted with the thicker edge **3** towards the front of the vehicle. Each end has a locking door **4** and two keys are supplied. Four PVC cushion strips **5** & **6** are supplied to fit into tracks **7** in the bars.

1

To protect the inside of your gutter, four V-shaped cushions **8** are supplied and should be fitted to the foot of the bar ends where they contact the inside of the gutter.

To protect the underside of your gutter, four rectangular flat pads **9** are supplied. Peel the backing tape from each pad and position it on the upper surface of the metal gutter grip **10** that protrudes from the base of each bar end door.

With the four locking doors **4** removed, extend the roof bars **11** and place in position on the vehicle roof with the bar ends inside the gutter profile. Firmly tighten (2 Newton metres) the two centre screws **12** on each bar to lock the telescoping sections to the required width.

2

Re-fit each locking door to the roof rack ends by placing the metal gutter grip **10** (with its cushion attached - see 1, above) under the roof gutter, and sit the door pivots **13** onto the pivot points. With the door partly open, adjust its two screws **14** evenly to bring the gutter grip **10** up tightly under the gutter. Closing the door will further increase the tension, securing the racks firmly to the gutter. Lock the doors and check that the racks are firm on the roof. To avoid lock damage, ensure that the doors are pressed firmly shut as you lock them.

3

PVC cushion strips **5** & **6** are supplied to fit the track **7** in each bar. Note that the wider strip **5** is for the inner bar and should be cut to length **15** only after the final bar length for your vehicle has been determined. To allow for shrinkage, strips should be 5mm longer than the track length. The narrower strip **6** is for the outer bar and should not need to be cut.

Fit the ends of each strip first, by pinching the edges together and fitting one edge first. Then work your way along the strip from each end towards the centre.

4

The track is designed to accept a range of RAK accessories that are designed to provide convenient and secure mounting of commonly-carried recreational equipment. If you have purchased accessories, you will need to cut the PVC cushion strips to fit the gaps in the tracks that are not occupied by the accessories. If you wish to remove the accessories from time to time, additional PVC cushion strips are available from RAK.

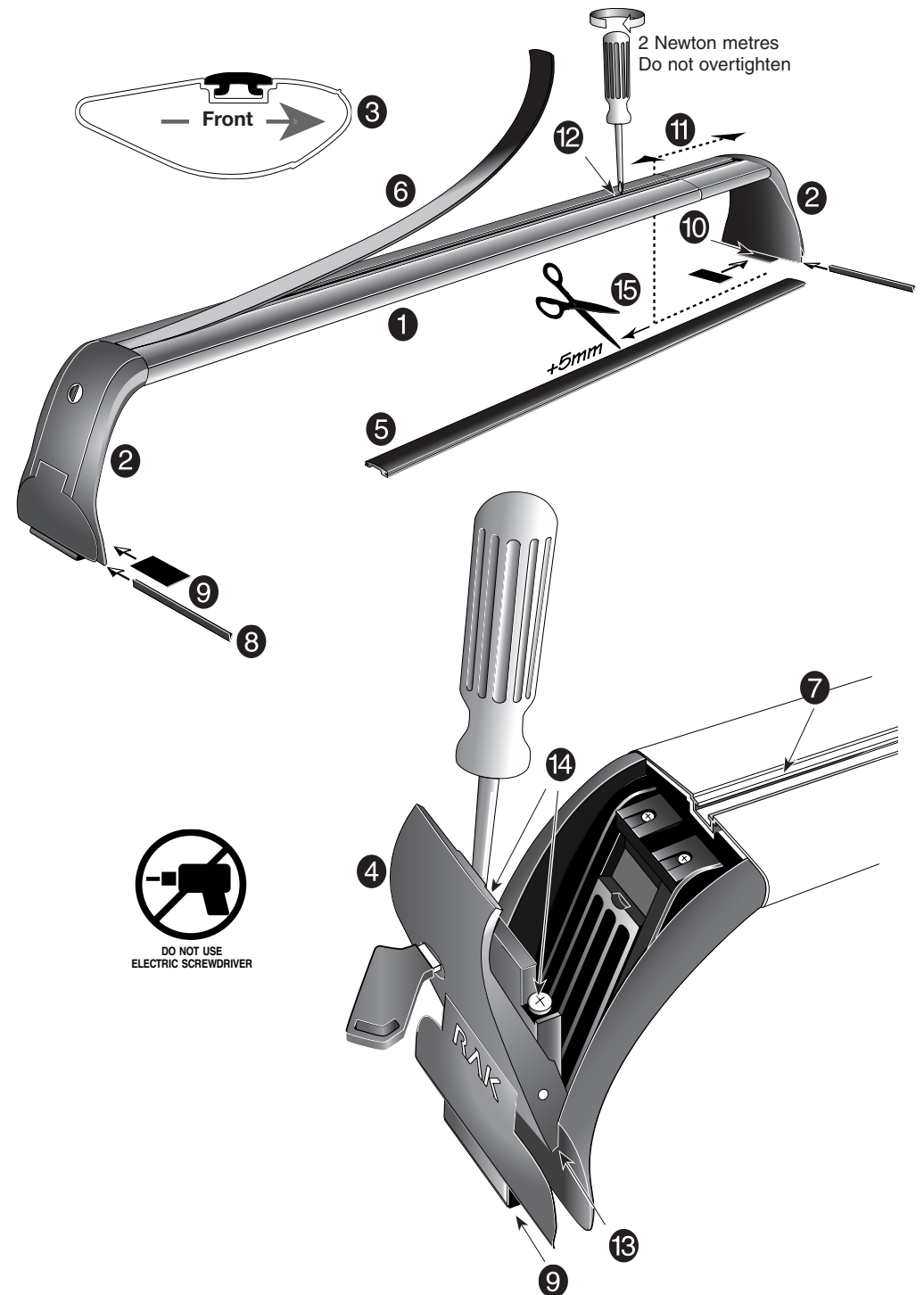

## IMPORTANT

Please remember that your new RAK system has been tested to Australian Standard AS1235-1989 (75kg load capacity) and is tougher than most vehicles to which it will be attached. While it is capable of carrying almost anything you might put on it, you should not exceed the maximum roof loading specified by the vehicle manufacturer.

Loads should not overhang your vehicle except as specified by your local traffic regulations. Long loads should be secured to front/rear bumper bars.

Before loading, always check that the system is fitted tightly and locked and check all fastenings regularly on extended trips. Check that your load is adequately secured and evenly distributed to minimise interference with your vehicle's roadhandling. Avoid roof damage by ensuring that your load will clear overhead obstacles and restricted garage entrances.

Roof loads affect vehicle handling: reduce speed, corner with care and beware of cross-winds.

## WARRANTY

This warranty gives the purchaser specific legal rights. The purchaser may also have other rights depending on state law. RAK hereby warrants to the original purchaser that the product sold by it is free from defects in material and workmanship for the period of three (3) years. The obligations of RAK under this warranty are limited to the repair and replacement of such part or parts of the unit as shall be found upon inspection to be defective in material or workmanship.

The warranty contained herein is expressly in lieu of any other warranties, including implied warranty of merchantability and/or fitness for purpose.

Warranty does not cover damages due to commercial use, misuse, abuse or accidents, negligence of the precaution, improper maintenance or fitting.

Any service done by a party other than a RAK agent during the warranty period voids the warranty.

---

## RAK accessories

The RAK accessory range includes a variety of clamps and strap systems to help ensure that your load is secure and presents no danger to other motorists. Pictured below are some of the RAK lockable accessories that make up the RAK system. For details of the latest products and prices, check the RAK website - [www.roofracks.com](http://www.roofracks.com), or post or fax the coupon below.



Ski/stock



Bicycle



Kayak



Uni-clamp



Belt/hook set



Spotlight/aerial



Mast clamp



Snowboard clamp



Extension rails



Quick-clamp straps



Tie-down

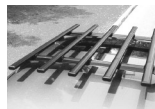

Luggage platform

---

Copy and post or fax to: RAK Australia, PO Box 588, Mona Vale, NSW 2103

Please send details on  accessories  a kit to adapt my existing RAK system to fit a:

Make \_\_\_\_\_ Model \_\_\_\_\_ Year \_\_\_\_\_

My customer number is \_\_\_\_\_ (or attach details of current vehicle)

Name \_\_\_\_\_ Address \_\_\_\_\_

Postcode \_\_\_\_\_

Daytime tel ( \_\_\_ ) \_\_\_\_\_ Fax ( \_\_\_ ) \_\_\_\_\_ e-mail \_\_\_\_\_