



## Type 2 Fitting Instructions

*After fitting, please keep these instructions with your other vehicle papers. Should you ever accidentally damage your RAK system or purchase another vehicle, your customer number will help us to provide you with the correct replacement parts.*

Congratulations on your choice of RAK, Australia's No.1 roof rack system.

As a RAK owner, you now have a versatile system that can be transferred from one vehicle to another. Unlike most roof rack systems, your RAK telescopic roof bars adjust to fit almost any vehicle, often needing only inexpensive adaptors should you wish to transfer them to a vehicle with a different roof profile.

Your purchase has been recorded along with your vehicle details. When you change vehicles, or if you wish to use the racks on more than one vehicle, just quote your customer number and the new vehicle details and we'll tell you which parts you will need to order.

We hope you'll be so pleased with your racks that you'll recommend RAK to friends. When you do, ask them to quote your customer number and we'll credit you with \$10 to use against future purchases of adaptors, accessories or a second set of racks.

Customer number .....  
Enter your Customer Purchase Order number here

Manufactured in Australia by RAK Australia, PO Box 588, Mona Vale Sydney NSW 2103  
Tel +61 2 997 2311 Fax +61 2 997 3533 e-mail: sales@roofracks.com

# roofracks.com

1

Your RAK roof rack system is supplied assembled and ready to fit. Included in the pack are two racks, each comprising a telescoping roof bar 1 with fitted ends 2 and roof straps 3, and four rubber pads 4 to protect your roof. Each end has a locking door 5 and two keys are supplied. Four PVC cushion strips 6&7 are supplied to fit into tracks 8 in the bars.

If your roof profile varies from front to rear, the bars will be labelled Front and Rear. The roof straps fitted to the bar ends may also vary in size and shape, so it is important that you do not remove any parts or mix front and rear bars. Note that the bars have an aerofoil shape and should be fitted with the thicker edge 9 towards the front of the vehicle.

2

Clean the roof to remove any dirt or grit where it will be contacted by the roof racks. Fit a rubber pad 4 to each roof rack end.

Remove the locking doors 5, extend the roof bars 10 and place in position (refer to your vehicle manufacturer's recommendations) on the vehicle roof. Loosen the two screws 11 to allow the feet 12 to roll to your roof angle.

The straps 3 at the base of the roof rack feet have been designed to fit the mounting points on your particular vehicle. These mounting points may be formed by ledges, holes or protrusions. The method of attachment appropriate for your vehicle may require that you peel back the rubber door seal or open mounting point cover plates (a fitting note is enclosed for your vehicle type).

In some cases it may be necessary to remove the straps 3, mount them to the vehicle and then refit the rack ends 2 on top of them. To do this you first remove the adjustment screw 13, refitting it once the strap is back in place.

Firmly tighten (2 Newton metres) the two centre screws 14 on each bar to lock the telescoping sections to the finished width. Once fitted neatly, tighten the adjustment screw 13 until the foot is firm on the roof. Lastly, tighten the two screws 11 to lock the foot after checking that it matches your roof angle.

3

Re-fit each locking door 5 to the roof rack ends. To avoid lock damage, ensure that the doors are pressed firmly shut as you lock them. Check that the racks are firm on the roof.

4

PVC cushion strips are supplied to fit the track in each bar. The narrower strip 7 is for the outer bar and should not need to be cut. Note that the wider strip 6 is for the inner bar and should not be cut to length 15 until the final bar length for your vehicle has been determined. To allow for shrinkage, strips should be 5mm longer than the track length.

Fit the ends of each strip first, by pinching the edges together and fitting one edge first. Then work your way along the strip from each end towards the centre.

The track is designed to accept a range of RAK accessories that are designed to provide convenient and secure mounting of commonly-carried recreational equipment. If you have purchased accessories, you will need to cut the PVC cushion strips to fit the gaps in the tracks that are not occupied by the accessories. If you wish to remove the accessories from time to time, additional PVC cushion strips are available from RAK.

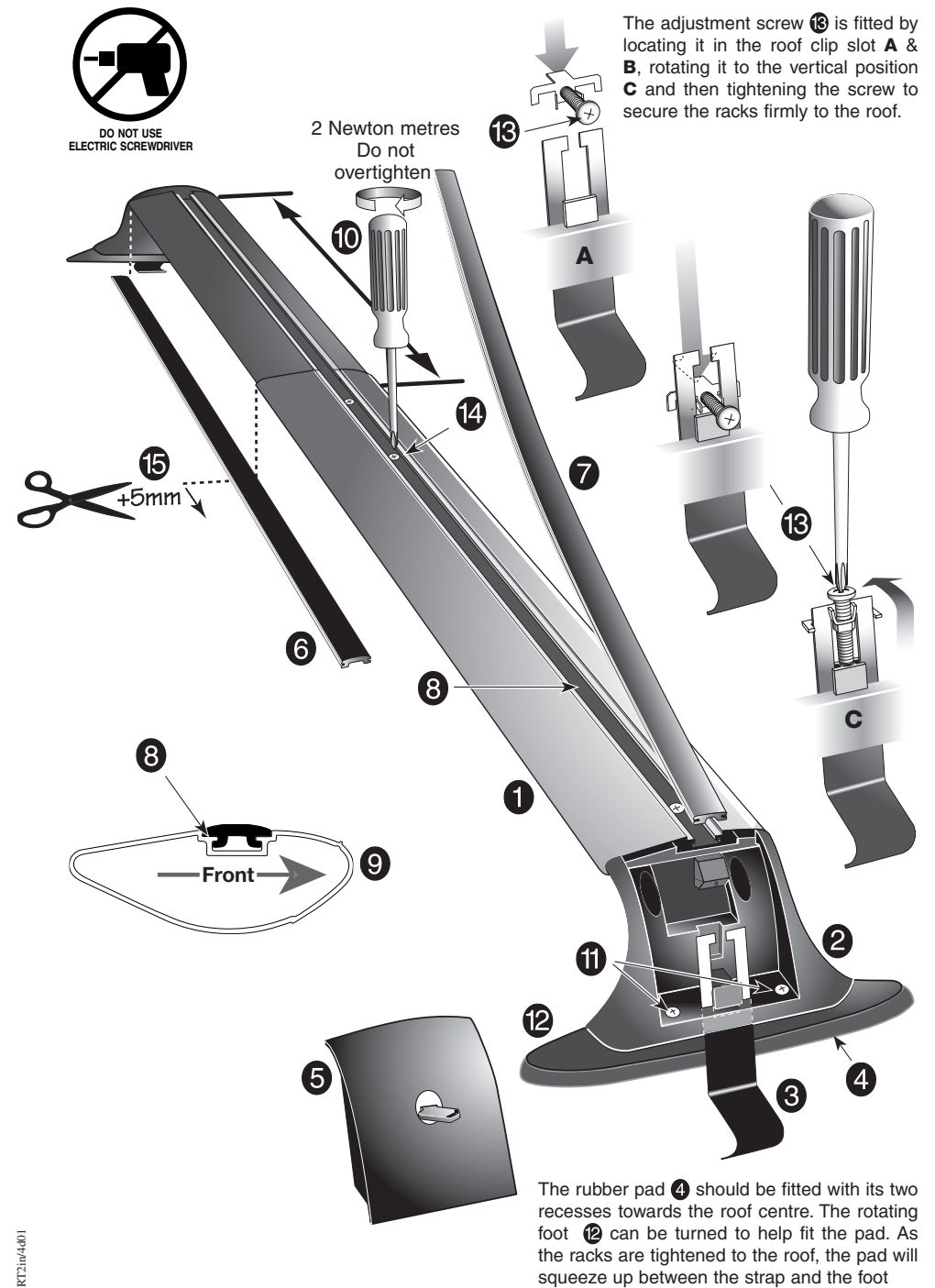

The adjustment screw 13 is fitted by locating it in the roof clip slot A & B, rotating it to the vertical position C and then tightening the screw to secure the racks firmly to the roof.

The rubber pad 4 should be fitted with its two recesses towards the roof centre. The rotating foot 12 can be turned to help fit the pad. As the racks are tightened to the roof, the pad will squeeze up between the strap and the foot

## IMPORTANT

Please remember that your new RAK system has been tested to Australian Standard AS1235-1989 (75kg load capacity) and is tougher than most vehicles to which it will be attached. While it is capable of carrying almost anything you might put on it, you should not exceed the maximum roof loading specified by the vehicle manufacturer.

Loads should not overhang your vehicle except as specified by your local traffic regulations. Long loads should be secured to front/rear bumper bars.

Before loading, always check that the system is fitted tightly and locked and check all fastenings regularly on extended trips. Check that your load is adequately secured and evenly distributed to minimise interference with your vehicle's roadhandling. Avoid roof damage by ensuring that your load will clear overhead obstacles and restricted garage entrances.

Roof loads affect vehicle handling: reduce speed, corner with care and beware of cross-winds.

## WARRANTY

This warranty gives the purchaser specific legal rights. The purchaser may also have other rights depending on state law. RAK hereby warrants to the original purchaser that the product sold by it is free from defects in material and workmanship for the period of three (3) years. The obligations of RAK under this warranty are limited to the repair and replacement of such part or parts of the unit as shall be found upon inspection to be defective in material or workmanship.

The warranty contained herein is expressly in lieu of any other warranties, including implied warranty of merchantability and/or fitness for purpose.

Warranty does not cover damages due to commercial use, misuse, abuse or accidents, negligence of the precaution, improper maintenance or fitting.

Any service done by a party other than a RAK agent during the warranty period voids the warranty.

---

## RAK accessories

The RAK accessory range includes a variety of clamps and strap systems to help ensure that your load is secure and presents no danger to other motorists. Pictured below are some of the RAK lockable accessories that make up the RAK system. For details of the latest products and prices, check the RAK website - [www.roofracks.com](http://www.roofracks.com), or post or fax the coupon below.



Ski/stock



Bicycle



Kayak



Uni-clamp



Belt/hook set



Spotlight/aerial



Mast clamp



Snowboard clamp



Extension rails



Quick-clamp straps



Tie-down

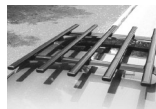

Luggage platform

---

Copy and post or fax to: RAK Australia, PO Box 588, Mona Vale, NSW 2103

Please send details on  accessories  a kit to adapt my existing RAK system to fit a:

Make \_\_\_\_\_ Model \_\_\_\_\_ Year \_\_\_\_\_

My customer number is \_\_\_\_\_ (or attach details of current vehicle)

Name \_\_\_\_\_ Address \_\_\_\_\_

Postcode \_\_\_\_\_

Daytime tel ( \_\_\_ ) \_\_\_\_\_ Fax ( \_\_\_ ) \_\_\_\_\_ e-mail \_\_\_\_\_